



US 20060179747A1

(19) **United States**

(12) **Patent Application Publication**  
**Crech**

(10) **Pub. No.: US 2006/0179747 A1**

(43) **Pub. Date: Aug. 17, 2006**

(54) **METHOD AND APPARATUS FOR INTEGRAL  
MODULAR MASONRY FLASHING**

(52) **U.S. Cl. .... 52/302.1**

(76) **Inventor: Claude S. Crech, Cumming, GA (US)**

(57) **ABSTRACT**

Correspondence Address:  
**BRYAN W. BOCKHOP, ESQ.**  
**2375 MOSSY BRANCH DR.**  
**SNELLVILLE, GA 30078 (US)**

A masonry wall includes a masonry foundation, a flashing unit disposed on the masonry foundation, a masonry weep structure, a mortar bed and at least one layer of masonry units disposed upon the mortar bed. A gap defined between the back surface of the masonry unit and the back edge is sufficient to allow water that has seeped through a plurality of masonry units to downwardly toward the platform. A mesh masonry weep structure is disposed on the platform of the flashing unit to allow drainage of water that has seeped behind the wall. A modular flashing unit and template system facilitates building a masonry foundation and quick application of flashing.

(21) **Appl. No.: 11/054,423**

(22) **Filed: Feb. 9, 2005**

**Publication Classification**

(51) **Int. Cl.**  
**E04B 1/70 (2006.01)**

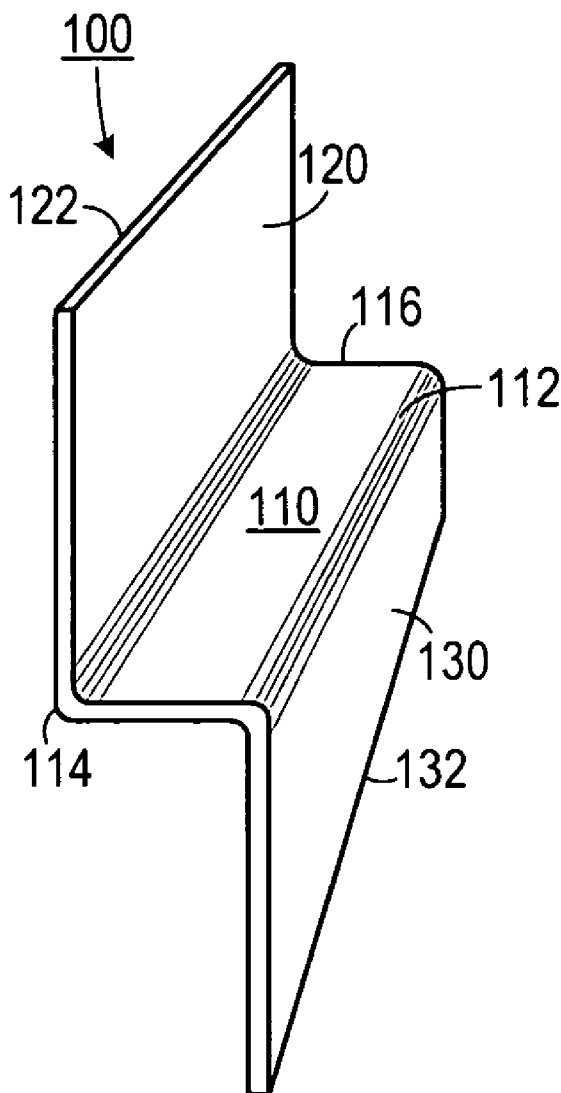

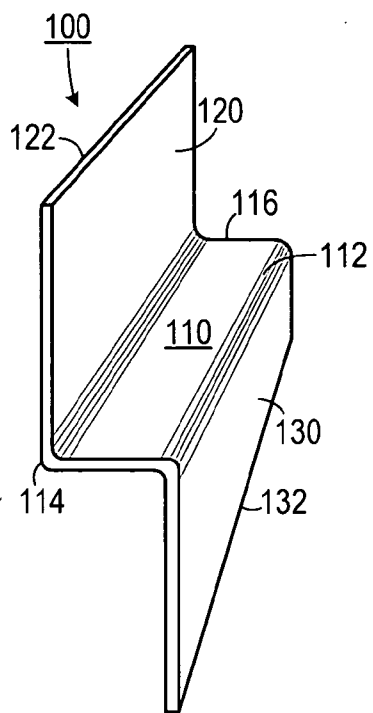

FIG. 1A

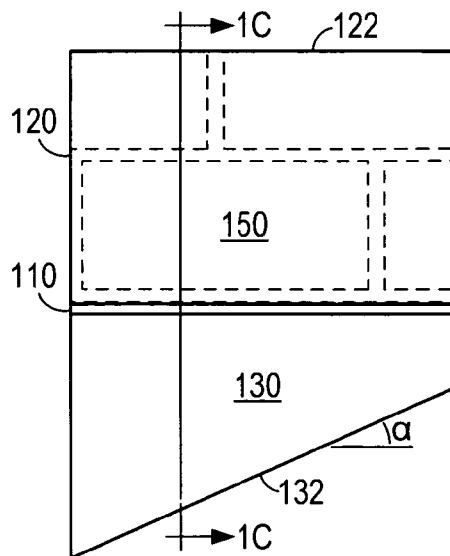

FIG. 1B

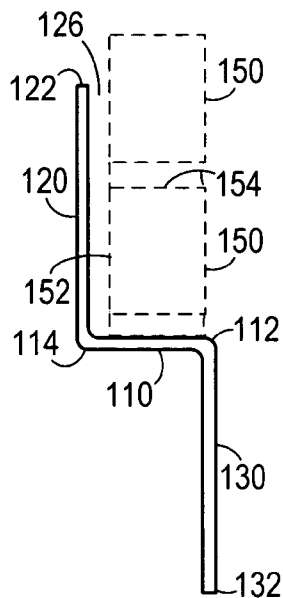

FIG. 1C

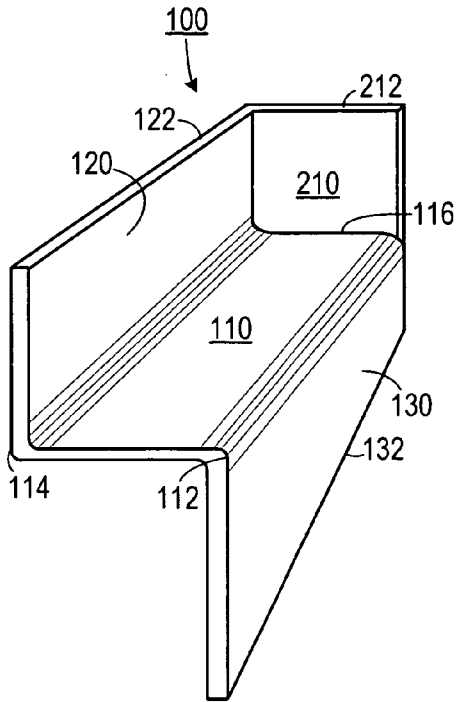

FIG. 2A

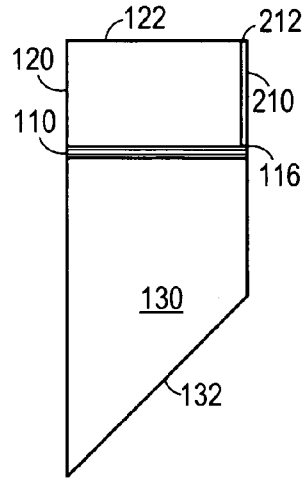

FIG. 2B

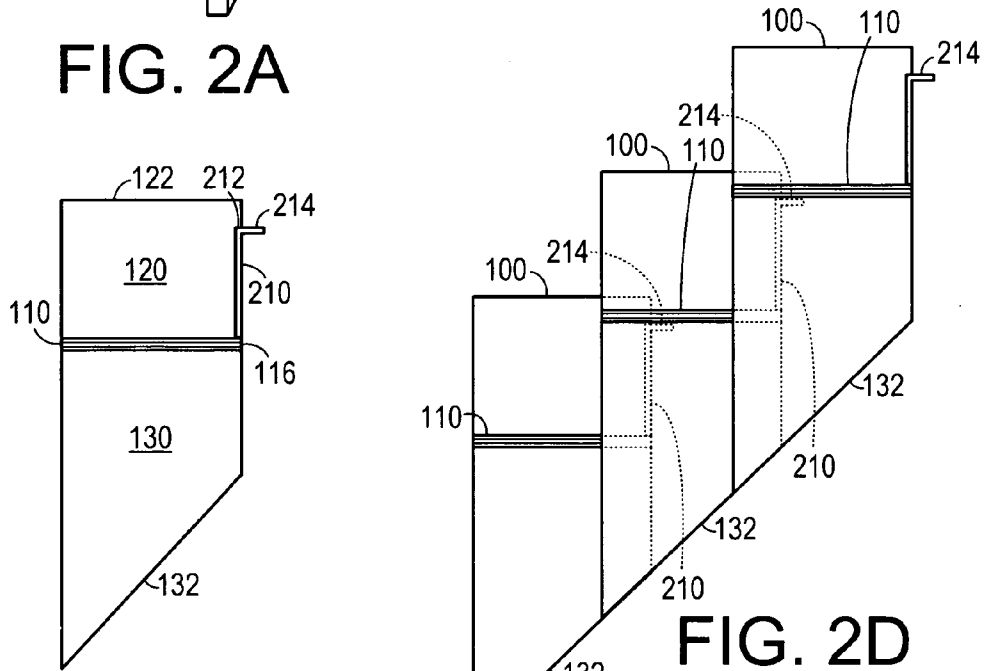

FIG. 2C

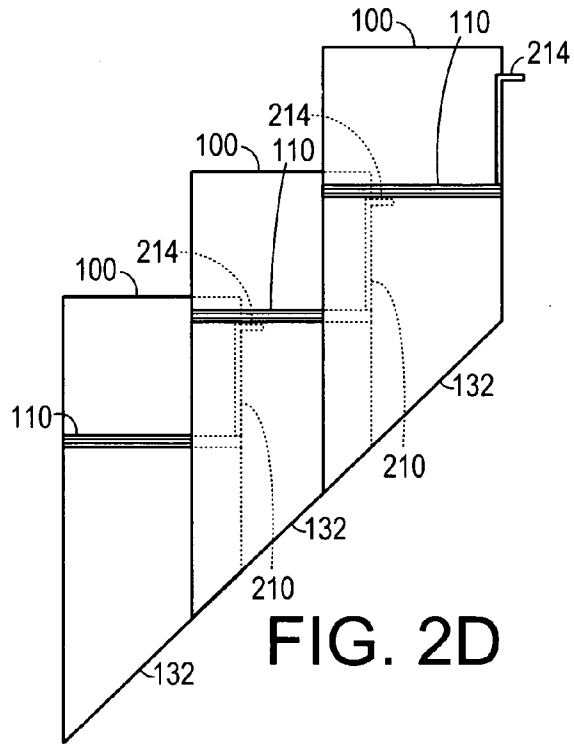

FIG. 2D

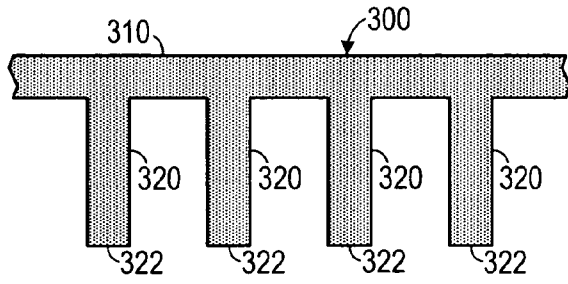

FIG. 3A



FIG. 3B

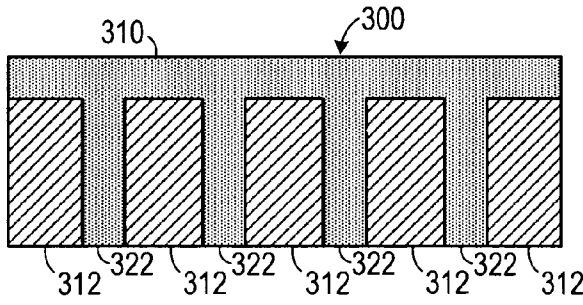

FIG. 3C

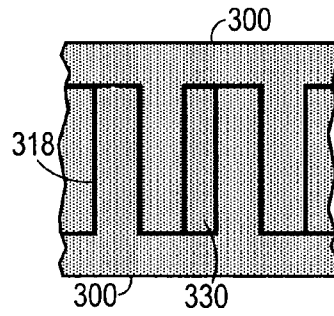

FIG. 3D

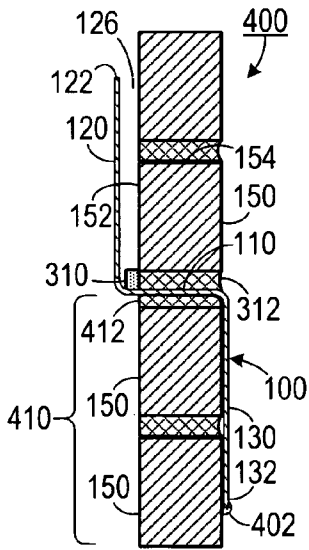

FIG. 4A

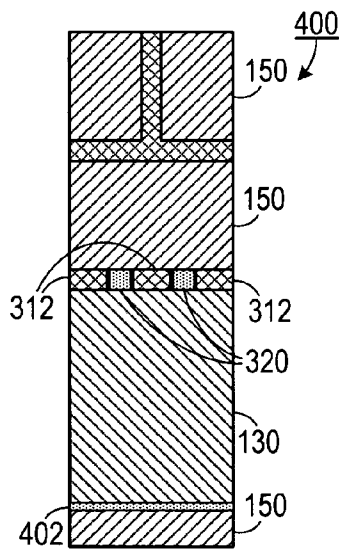

FIG. 4B

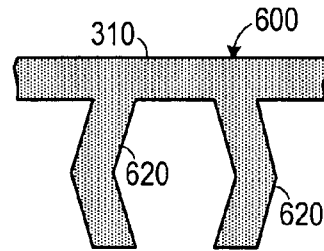
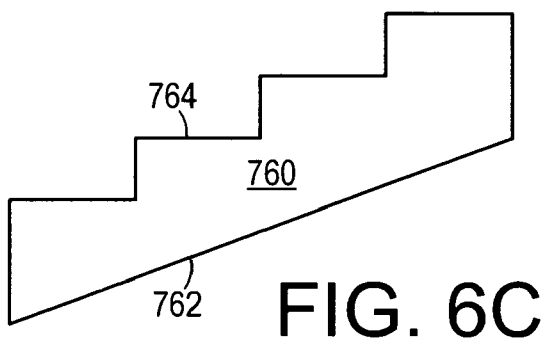
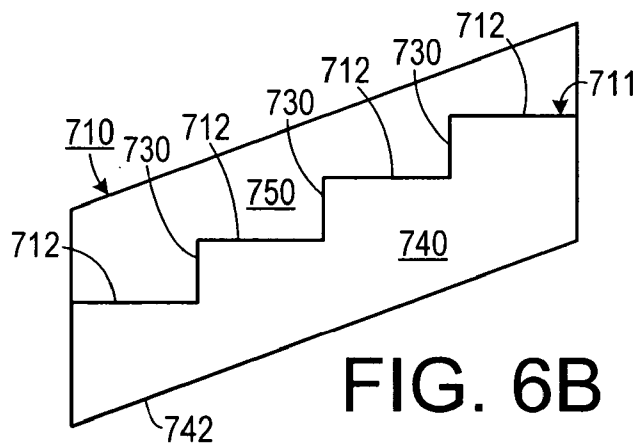
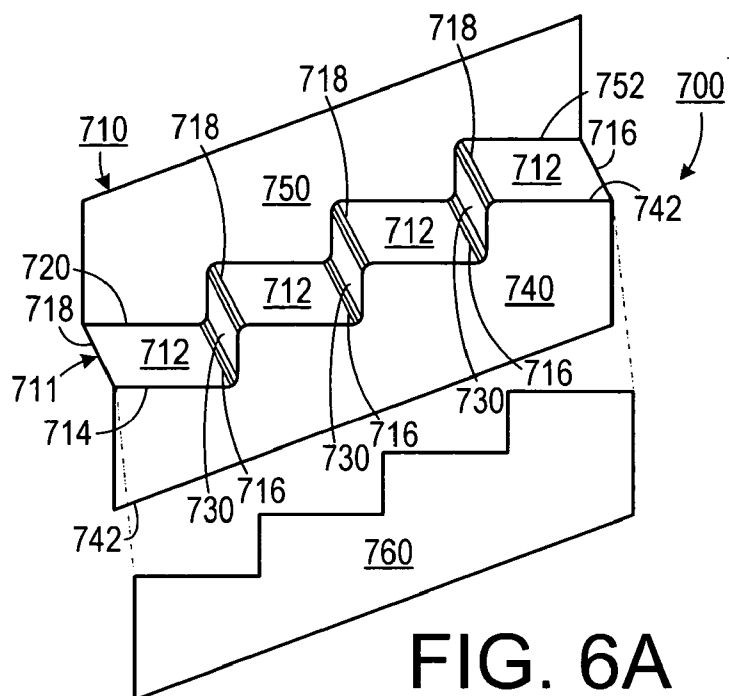

FIG. 5



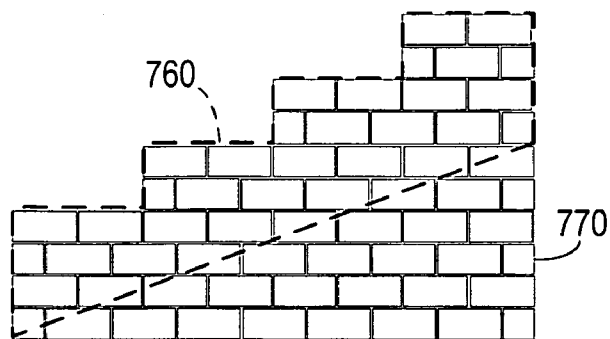

FIG. 6D

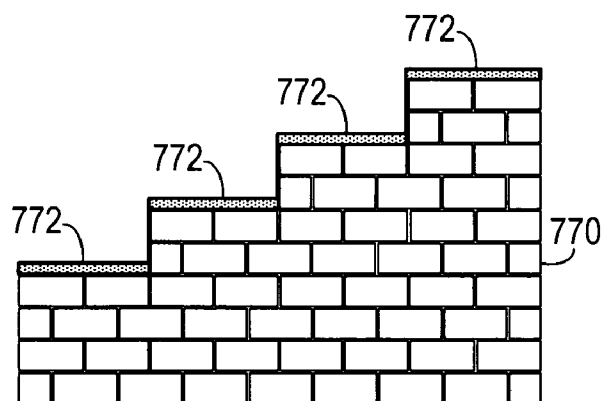

FIG. 6E

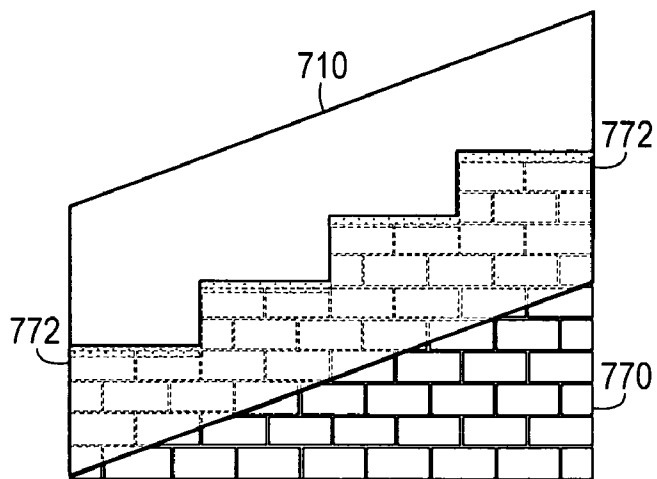

FIG. 6F

**METHOD AND APPARATUS FOR INTEGRAL MODULAR MASONRY FLASHING**

**BACKGROUND OF THE INVENTION**

[0001] 1. Field of the Invention

[0002] The present invention relates to masonry and, more specifically, to a thru-wall masonry flashing system.

[0003] 2. Description of the Prior Art

[0004] Typical masonry veneer walls are made by laying a plurality of bricks (or other masonry units, such as stones) in an ordered arrangement. With a veneer wall, the structural support for the wall is typically a wood or steel frame and the masonry veneer functions aesthetically.

[0005] Typically, rainwater is absorbed through masonry veneer in a very short amount of time. In such a case, a mechanism must be in place to prevent the structural components of the wall and other building assemblies and components from becoming wet. This is typically done by employing thru wall flashing and weep structures. Thru wall flashing is a sheet structure placed at the bottom regions of a masonry veneer, at intersections and terminations, providing moisture barrier protection that allows water to collect and travel in a gap between a vertical portion of the thru wall flashing and the rear surface of the veneer. Water is allowed to drain out of the veneer through the weep structure, which is typically a plastic tube, wicking rope or other type of weep, embedded in the mortar at the bottom of the veneer and on top of the thru wall flashing platform.

[0006] Frequently, the masonry veneer must interface with a structure. For example, an angled roof may intersect with the masonry veneer of a wall. In such an intersection, a stair-stepped structure of masonry and thru wall flashing is built up by the mason. Once the veneer is complete, a roofer applies counter flashing to the part of the thru wall flashing extending beyond the outer surface of the veneer. The counter flashing interfaces the veneer with the roof line.

[0007] Existing thru wall flashing units are typically made at the job site from sheet metal by masons or sheet metal fabricators. Doing so can be time consuming and costly. The additional step of applying counter flashing adds to the time consumed and the cost.

[0008] Also, existing weep structures tend to get clogged with mortar droppings generated by masons. If the weep structures get clogged, then drainage through the veneer and cavity wall ventilation is hampered, thereby increasing the likelihood of moisture-related problems in the frame structure of the wall assemblies and components.

[0009] Therefore, there is a need for a flashing system that is relatively inexpensive, reliable and easy to use.

[0010] There is also a need for a flashing system that incorporates both thru wall flashing and counter flashing in a single unit.

[0011] There is also a need for a weep structure that resists clogging.

**SUMMARY OF THE INVENTION**

[0012] The disadvantages of the prior art are overcome by the present invention which, in one aspect, is a masonry wall

that includes a masonry foundation, a flashing unit disposed on the masonry foundation, a masonry weep structure, a mortar bed and at least one layer of masonry units disposed upon the mortar bed. The masonry flashing unit includes a platform having a front edge and an opposite back edge. The masonry flashing unit has a width between the front edge and the back edge so that when a masonry unit is disposed on the platform with the front surface substantially flush with the front edge, a gap of predetermined width is defined between the back surface of the masonry unit and the back edge. The predetermined width is sufficient to allow water that has seeped through a plurality of masonry units to downwardly toward the platform. A back vertical wall, having a top edge, extends upwardly from the back edge of the platform. The back vertical wall has a height so that the top edge extends by a predetermined amount beyond the top surface of a brick of a plurality of masonry units placed on the platform. A front vertical wall depends downwardly from the front edge of the platform. A masonry weep structure is disposed on the platform of the flashing unit. The masonry weep structure includes a first elongated mesh strip and a first plurality of spaced-apart mesh fingers extending from the elongated mesh strip. Each finger extends from the elongated mesh strip at a distance at least equal to a width of a masonry unit. The mesh strip and the mesh fingers are made of a mesh material that allows water to pass there-through and that is stable in the presence of mortar. The mesh fingers terminate in a front surface that is in alignment with the front edge of the platform. The mortar bed is disposed on the platform of the flashing unit so as to fill in a space between the spaced-apart mesh fingers. The masonry units are disposed upon the mortar bed and the spaced-apart mesh fingers. The layer of masonry units has a back surface that is spaced-apart from the back vertical wall of the flashing unit by a predetermined distance sufficient to allow water that has seeped through the masonry units to flow downwardly to the first elongated mesh strip and through the spaced-apart mesh fingers.

[0013] In another aspect, the invention is a masonry flashing unit for use with a plurality masonry units wherein each masonry unit has a front surface, an opposite back surface, a bottom surface and an opposite top surface. The masonry flashing unit includes a platform, a back vertical wall and a front vertical wall. The platform has a front edge and an opposite back edge. The back vertical wall has a top edge and extends upwardly from the back edge of the platform. The back vertical wall has a height so that the top edge extends by a predetermined amount beyond the top surface of a masonry unit of the plurality of masonry units placed on the platform. The front vertical wall depends downwardly from the front edge of the platform. The platform has a width between the front edge and the back edge so that when a masonry unit of the plurality of masonry units is disposed on the platform with the front surface substantially flush with the front edge, a gap of predetermined width is defined between the back surface of the masonry unit and the back vertical wall. The predetermined width is sufficient to allow water that has seeped through the plurality of masonry units to run down the back vertical wall.

[0014] In another aspect, the invention is a modular flashing unit for use with a plurality masonry units in which each masonry unit has a front surface, an opposite back surface, a bottom surface and an opposite top surface. The modular flashing unit includes a stepped member, a front vertical wall

and a back vertical wall. The stepped member includes at least a first latitudinal platform and a second latitudinal platform. The second latitudinal platform is not coplanar with the first latitudinal platform. Each of the first latitudinal platform and the second latitudinal platform has a front edge, an opposite back edge, a first side edge and an opposite second side edge. The stepped member also includes at least one longitudinal wall connecting the first side edge of the first latitudinal platform to the second side edge of the second latitudinal platform. The longitudinal wall includes a front edge and an opposite back edge. The stepped member has a width between the first latitudinal platform and the second latitudinal platform that is wider than a masonry unit of the plurality of masonry units by a predetermined amount. The front vertical wall has a stepped edge connected to the front edge of the first latitudinal platform, the front edge of the second latitudinal platform and the front edge of the longitudinal wall. The back vertical wall has a stepped edge that is connected to the back edge of the first latitudinal platform, the back edge of the second latitudinal platform and the back edge of the longitudinal wall.

[0015] In another aspect, the invention is a masonry weep system that includes a mesh finger, having a first side, an opposite second side, a front end and an opposite back end. The mesh finger is made of a mesh material that allows water to pass therethrough and that is stable in the presence of mortar. The mesh finger placed on a masonry foundation. Mortar is placed on the masonry foundation and is disposed about the first side and the second side of the mesh finger and does not cover the back end or the front end.

[0016] In another aspect, the invention is a masonry weep structure that includes a first elongated mesh strip and a first plurality of spaced-apart mesh fingers that extend from the elongated mesh strip. Each finger extends from the elongated mesh strip at a distance at least equal to a width of a masonry unit. The mesh strip and the mesh fingers are made of a mesh material that allows water to pass therethrough and that is stable in the presence of mortar.

[0017] In yet another aspect, the invention is a method of making a modular flashing system for a user to employ with a masonry foundation. Dimensions corresponding to the masonry foundation are received. A modular flashing system that is sized to fit the masonry foundation is made based on the dimensions. A template that has an edge that corresponds to an edge of the masonry foundation is made. The template is delivered to the user so that when the user builds the masonry foundation according to the template, the modular flashing system will fit the masonry foundation.

[0018] These and other aspects of the invention will become apparent from the following description of the preferred embodiments taken in conjunction with the following drawings. As would be obvious to one skilled in the art, many variations and modifications of the invention may be effected without departing from the spirit and scope of the novel concepts of the disclosure.

BRIEF DESCRIPTION OF THE FIGURES OF THE DRAWINGS

[0019] FIG. 1A is a top perspective view of one embodiment of a flashing unit.

[0020] FIG. 1B is a front elevational view of the embodiment shown in FIG. 1A.

[0021] FIG. 1C is a cross sectional view of the embodiment shown in FIG. 1B, taken along line 1C-1C.

[0022] FIG. 2A is a top perspective view of a second embodiment of a flashing unit.

[0023] FIG. 2B is a front elevational view of the embodiment shown in FIG. 1B.

[0024] FIG. 2C is a front elevational view of a third embodiment of a flashing unit.

[0025] FIG. 2D is a front elevational view of several flashing units, as shown in FIG. 2C, used together.

[0026] FIG. 3A is a plan view of one embodiment of a weep structure.

[0027] FIG. 3B is a cross-sectional view of mesh used in a weep structure.

[0028] FIG. 3C is a plan view of a weep structure, as shown in FIG. 3A, used with mortar.

[0029] FIG. 3D is a plan view of a weep structure strip.

[0030] FIG. 4A is a cross-sectional view of a flashing unit, a weep structure and masonry units used together to form a masonry wall.

[0031] FIG. 4B is a front elevational view of the wall shown in FIG. 4A.

[0032] FIG. 5 is a plan view of a second embodiment of a weep structure.

[0033] FIG. 6A is a top perspective view of a modular flashing system.

[0034] FIG. 6B is a front elevational view of a stepped member of a modular flashing unit.

[0035] FIG. 6C is a front elevational view of a flashing template.

[0036] FIG. 6D is a front elevational view of a flashing template applied to a masonry foundation.

[0037] FIG. 6E is a front elevational view of a masonry foundation made according to the template shown in FIG. 6D.

[0038] FIG. 6F is a front elevational view of the masonry foundation shown in FIG. 6E, with the stepped member shown in FIG. 6B applied thereto.

DETAILED DESCRIPTION OF THE INVENTION

[0039] A preferred embodiment of the invention is now described in detail. Referring to the drawings, like numbers indicate like parts throughout the views. As used in the description herein and throughout the claims, the following terms take the meanings explicitly associated herein, unless the context clearly dictates otherwise: the meaning of “a,” “an,” and “the” includes plural reference, the meaning of “in” includes “in” and “on.” “Masonry unit” includes any unit of solid masonry material, including a brick, a concrete block, a ceramic block, a glass block, a piece of stone, or any unit of any other type of material that is used to make a masonry wall. “Mortar” includes cement, grout and any substance used to bind masonry units.

[0040] As shown in FIGS. 1A-1C, one embodiment of the invention is a thru-wall masonry flashing unit 100 that includes a platform 110 having a front edge 112, an opposite back edge 114 and a first side edge 116. A back vertical wall 120, having a top edge 122, extends upwardly from the back edge 114 of the platform 110. The back vertical wall 120 has a height so that the top edge 122 extends by a predetermined amount (typically two inches) beyond the top surface 154 of a masonry unit 150 (such as a brick) of the plurality of masonry units 150 placed on the platform 110. A front vertical wall 130 depends downwardly from the front edge 112 of the platform 110. The width of the platform 110 between the front edge 112 and the back edge 114 is sufficient so that a gap 126 is defined between the back vertical wall 120 and the back surface 152 of masonry units 150 placed on the platform 110 so that the front surface 156 of the masonry units 150 are aligned with the front vertical wall 130. The gap 126 is wide enough (typically one inch) to allow water that has seeped through the plurality of masonry units 150 to run down the back vertical wall 120 to the platform 110. The front vertical wall 130 has a bottom edge 132 that may be either flat or at an angle  $\alpha$ , depending on the location where the masonry flashing unit 100 is being used. The platform 110, the front vertical wall 130 and the back vertical wall 120 may be formed from a single piece of a material, such as sheet metal (e.g., copper, aluminum, or galvanized steel) or plastic (e.g., PVC, HDPE, composites, laminates). If a sheet thermoplastic is used, the embodiments of the flashing units shown herein can be made through vacuum forming.

[0041] As shown in FIGS. 2A-2B, a vertical side wall 210, having a top edge 212, can extend upwardly from the first side edge 116. As shown in FIG. 2C, a lip 214 can be formed in the vertical side wall 210. The lip 214 can be manufactured at a manufacturing facility, or it can be formed at the job site using a pair of metal shears and a pair of pliers. As shown in FIG. 2D, if the height of the vertical side wall 210 of masonry flashing units 100 is chosen correctly, they can be stacked so that their bottom edges 132 are in substantial alignment. This is a useful feature when it is desirable for the bottom edges 132 are to follow a roof line. By having the platforms 110 overlap the vertical side walls 210, water flowing through the masonry units into the flashing units 100 will not leak out of the flashing units 100 into the frame structure about which the masonry is being applied.

[0042] A weep structure may be used with the flashing units 100 disclosed herein. While a conventional weep structure, such as a plastic tube, may be used to drain water from the gap 126, a mesh-type weep structure 300, as shown in FIG. 3A, offers several advantages. Such a weep structure 300 includes a first elongated mesh strip 310 and a first plurality of spaced apart mesh fingers 320, each extending from the elongated mesh strip 310. Each finger 320 is at least as long as a masonry unit is wide. As shown in FIG. 3B, the mesh strip 310 and the mesh fingers 320 are made of a mesh material 302, shown in FIG. 3B, that allows water to pass therethrough and that is stable in the presence of mortar. The mesh fingers 320 terminate in a front surface 322. Examples of a suitable mesh material 302 include a nonwoven thermoplastic mesh (such as a polyester fiber mesh). One example of a suitable mesh is COBRA® RIDGE VENT, available from Cobra Ventilation Co., Inc., 1361 Alps Road, Wayne, N.J. 07470-3689. As shown in FIG. 3C, the weep

structure 300 may be used with a mortar bed 312, to allow water to drain out of a masonry structure. As shown in FIG. 3D, the mesh-type weep structure 300, may be sold as a mesh strip that includes tear lines 318 that allow the contractor to separate two cross-positioned weep structures 300 by tearing them apart. Additional pieces 330 of mesh may also be included in the strip. Such pieces 330 of mesh may be used for individual weeps. As shown in FIG. 6, a shaped mesh weep structure 600 may be made in which the fingers 620 are shaped for esthetic or branding purposes.

[0043] As shown in FIGS. 4A and 4B, a masonry wall 400 may be made according to one embodiment of the invention. The wall 400 includes a foundation 410, typically made of several layers masonry units 150 topped with a mortar bed 412. Before hardening of the mortar bed 412, a flashing unit 100 is placed on the mortar bed 412. The weep structure 300 is then placed on the platform 110 of the flashing unit 100 and a layer of mortar 312 is applied between the fingers 320. Upon this combination of the weep structure 300 and the mortar 312 is placed the masonry units 150 that make up the wall 400. A bead of caulk 402 may be applied to the bottom edge 132 of the front vertical wall 130 to provide a more esthetic appearance.

[0044] One embodiment of a modular flashing system 700 is shown in FIGS. 6A-6C. The modular flashing system 700 includes a modular flashing unit 710 and a corresponding planar template 760. The modular flashing unit 710 includes a stepped member 711, a front vertical wall 740, and a back vertical wall 750. The stepped member 711 includes a plurality of latitudinal platforms 712 connected by longitudinal walls 730 to form a stepped shape. The stepped member 711 has a front edge 732, an opposite back edge 734, a first side edge 716 and an opposite second side edge 718. The front vertical wall 740 has a stepped edge 742 connected to the front edge 714 of the stepped member 711. The front vertical wall 740 also includes a bottom edge 742. The back vertical wall 750 has a stepped edge 752 connected to the back edge 720 of the stepped member 711.

[0045] As shown in FIGS. 7A and 7C, the planar template 760 has dimensions that correspond to the front vertical wall 740 of the modular flashing unit 710. The planar template 760 has a top stepped edge 764 and a bottom angled edge 762. As shown in FIG. 7D, the planar template 760 is used as a template to build a masonry foundation 770. The masonry foundation 770 is the foundation upon which the modular flashing unit 710 will be installed.

[0046] As shown in FIGS. 7E and 7F, once the masonry foundation 770 is complete, a mortar bed 772 is placed on the masonry foundation 770 and the modular flashing unit 710 is placed on the mortar bed 772 before it sets. This ensures a good fit for the modular flashing unit 710 and ensures that it is well supported by the masonry foundation 770.

[0047] The modular flashing unit 710 could be made in one of several ways. For example, it could be made from sheet metal using conventional metalworking techniques. Similarly, it could be made from sheet plastic using conventional plastic fabrication techniques, including vacuum forming. The planar template 760 could be made from one of many sheet materials, including metal, plastic or even sturdy cardboard.

[0048] In one method of making the modular flashing unit 710, a builder or architect sends the dimensions for the

masonry foundation 770 to a fabrication facility. The fabrication facility would employ a conventional computer-aided design and manufacturing (CAD/CAM) system to design the modular flashing unit 710 and the planar template 760, using predefined criteria, based on the dimensions. The CAD/CAM system would control the necessary cutting tools (such as a LASER cutting tool) to cut out the necessary parts.

[0049] In one embodiment, a sheet cutting facility or a stair manufacturer, could make two copies of the planar template 760, each of which is marked with a unique identifier that corresponds to the specific use specified by the builder. One of the dual twin templates is sent to the mason; thereby allowing the building of the masonry foundation 770 to commence, and the other is sent to a fabrication facility for use in the fabrication of the modular flashing unit 710. Making the masonry foundation 770 in tandem with the planar template 760 allows for efficient workflow.

[0050] The above described embodiments are given as illustrative examples only. It will be readily appreciated that many deviations may be made from the specific embodiments disclosed in this specification without departing from the invention. Accordingly, the scope of the invention is to be determined by the claims below rather than being limited to the specifically described embodiments above.

What is claimed is:

- 1. A masonry wall, comprising:
  - a. a foundation;
  - b. a flashing unit disposed on the foundation, the masonry flashing unit comprising:
    - i. a platform having a front edge and an opposite back edge and having a width between the front edge and the back edge so that when a masonry unit is disposed on the platform with a front surface substantially flush with the front edge, a gap is defined between the back surface of the masonry unit and the back edge;
    - ii. a back vertical wall, having a top edge, extending upwardly from the back edge of the platform, the back vertical wall having a height so that the top edge extends by a predetermined amount beyond the top surface of a masonry unit of a plurality of masonry units placed on the platform; and
    - iii. a front vertical wall depending downwardly from the front edge of the platform;
  - c. a masonry weep structure placed on the platform of the flashing unit, the masonry weep structure including:
    - i. a first elongated mesh strip; and
    - ii. a first plurality of spaced-apart mesh fingers extending from the elongated mesh strip, each finger extending from the elongated mesh strip at a distance at least equal to a width of a masonry unit, the mesh strip and the mesh fingers made of a mesh material that allows water to pass therethrough and that is stable in the presence of mortar, the mesh fingers terminating in a front surface that is in alignment with the front edge of the platform;

- d. a mortar bed disposed on the platform of the flashing unit so as to fill in a space between the spaced-apart mesh fingers; and

at least one layer of masonry units disposed upon the mortar bed and the spaced-apart mesh fingers, the layer having a back surface that is spaced-apart from the back vertical wall of the flashing unit by a predetermined distance sufficient to allow water that has seeped through the masonry units to flow down to first elongated mesh strip and through the spaced-apart mesh fingers.

2. A masonry flashing unit for use with a plurality masonry units, each masonry unit having a front surface, an opposite back surface, a bottom surface and an opposite top surface, the masonry flashing unit comprising:

- a. a platform having a front edge and an opposite back edge;
- b. a back vertical wall, having a top edge, extending upwardly from the back edge of the platform, the back vertical wall having a height so that the top edge extends by a predetermined amount beyond the top surface of a masonry unit of the plurality of masonry units placed on the platform; and
- c. a front vertical wall depending downwardly from the front edge of the platform,

the platform having a width between the front edge and the back edge so that when a masonry unit of the plurality of masonry units is disposed on the platform with the front surface substantially flush with the front edge, a gap of predetermined width is defined between the back surface of the masonry unit and the back vertical wall, the predetermined width being sufficient to allow water that has seeped through the plurality of masonry units to flow downwardly to the platform.

3. The masonry flashing unit of claim 2, wherein the platform, the front vertical wall and the back vertical wall are formed from a single piece of a material.

4. The masonry flashing unit of claim 3, wherein the material is selected from a group consisting essentially of: a metal and a plastic.

5. The masonry flashing unit of claim 2, wherein the front vertical wall defines a bottom edge, wherein the bottom edge is at an angle that is transverse to the platform.

6. The masonry flashing unit of claim 5, wherein the platform has a side edge, the masonry flashing unit further comprising a vertical side wall, having a top edge, extending upwardly from the side edge.

7. The masonry flashing unit of claim 6, further comprising a lip extending outwardly from the top edge of the vertical side wall.

8. The masonry flashing unit of claim 6, wherein the vertical side wall has a height so that when a first masonry flashing unit is placed on top of a second masonry flashing unit so that the platform of the second masonry flashing unit rests on the top edge of the vertical side wall of the first masonry flashing unit and so that the platform of the second modular flashing unit overlaps the vertical sidewall of the first modular flashing unit, the bottom edge of the front vertical wall of the first modular flashing unit is in substantial alignment with the bottom edge of the front vertical wall of the second modular flashing unit.

9. A modular flashing unit for use with a plurality masonry units, each masonry unit having a front surface, an opposite back surface, a bottom surface and an opposite top surface, the modular flashing unit comprising

- a. a stepped member including at least a first latitudinal platform and a second latitudinal platform, the second latitudinal platform being not coplanar with the first latitudinal platform, each of the first latitudinal platform and the second latitudinal platform having a front edge, an opposite back edge, a first side edge and an opposite second side edge, the stepped member also including at least one longitudinal wall connecting the first side edge of the first latitudinal platform to the second side edge of the second latitudinal platform, the longitudinal wall including a front edge and an opposite back edge, the stepped member having a width between the first latitudinal platform and the second latitudinal platform that is wider than a masonry unit of the plurality of masonry units by a predetermined amount;
- b. a front vertical wall having a stepped edge connected to the front edge of the first latitudinal platform, the front edge of the second latitudinal platform and the front edge of the longitudinal wall; and
- c. a back vertical wall having a stepped edge connected to the back edge of the first latitudinal platform, the back edge of the second latitudinal platform and the back edge of the longitudinal wall.

10. The modular flashing unit of claim 9, further comprising a planar template that has dimensions corresponding to a masonry foundation upon which the modular flashing unit is to be installed, so that when the masonry foundation is made according to the template, the modular flashing unit will fit on the masonry foundation.

11. The modular flashing unit of claim 9, wherein the stepped member, the front vertical wall, and the back vertical wall are all made from a unitary sheet of a material.

12. The modular flashing unit of claim 11, wherein the material comprises a plastic.

13. The modular flashing unit of claim 12, wherein the plastic has been vacuum-formed.

14. A masonry weep system, comprising:

- a. a mesh finger, having a first side, an opposite second side, a front end and an opposite back end, the mesh finger made of a mesh material that allows water to pass therethrough and that is stable in the presence of mortar, the mesh finger placed on a masonry foundation; and

b. mortar placed on the masonry foundation and disposed about the first side and the second side of the mesh finger and not covering the back end or the front end.

15. A masonry weep structure, comprising:

- a. a first elongated mesh strip; and
- b. a first plurality of spaced-apart mesh fingers extending from the elongated mesh strip, each finger extending from the elongated mesh strip at a distance at least equal to a width of a masonry unit,

the mesh strip and the mesh fingers made of a mesh material that allows water to pass therethrough and that is stable in the presence of mortar.

16. The masonry weep structure of claim 15, wherein the mesh strip and the mesh fingers comprise a non-woven plastic mesh.

17. The masonry weep structure of claim 15, further comprising:

- a. a second elongated mesh strip; and
- b. a second plurality of spaced-apart mesh fingers extending from the elongated mesh strip, each finger extending from the elongated mesh strip at a distance at least equal to a width of a masonry unit,

the second elongated strip and the second plurality of spaced-apart mesh fingers in opposed engagement with the first elongated mesh strip and the first plurality of spaced-apart mesh fingers, so as to form a single belt of mesh with division to facilitate separation of the first elongated mesh strip and the first plurality of spaced apart mesh fingers from the second elongated mesh strip and the second plurality of spaced-apart mesh fingers.

18. A method of making a modular flashing system for a user to employ with a masonry foundation, comprising the steps of:

- a. receiving dimensions corresponding to the masonry foundation;
- b. making a modular flashing system that is sized to fit the masonry foundation, based on the dimensions;
- c. making a template that has an edge that corresponds to an edge of the masonry foundation; and
- d. delivering the template to the user so that when the user builds the masonry foundation according to the template, the modular flashing system will fit the masonry foundation.

\* \* \* \* \*